

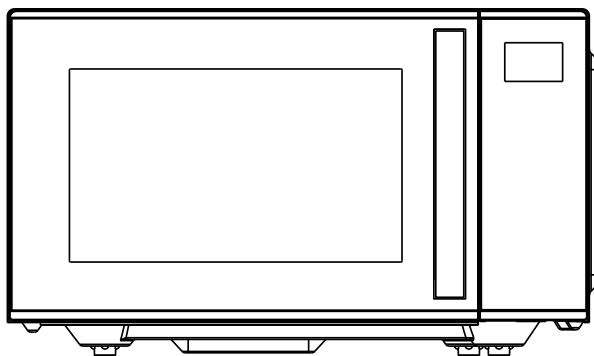

30 L Digital Microwave Oven with Grill User Manual

Model Number: H30MWS



**IMPORTANT SAFETY INSTRUCTIONS
READ CAREFULLY AND KEEP FOR FUTURE REFERENCE**

IMPORTANT SAFEGUARDS

When using any electrically powered product, basic safety precautions should always be followed, including the following:

PLEASE READ ALL INSTRUCTIONS CAREFULLY BEFORE USING THIS PRODUCT
WARNING! - to reduce the risk of fire, electrical shock or injury to persons or property:

When using electrical appliance basic safety precautions should be followed, including the following:

WARNING! --To reduce the risk of burns, electric shock, fire, injury to persons or exposure to excessive microwave energy:

1. Use this appliance only for its intended use as described in the manual. Do not use corrosive chemicals or vapors in this appliance. This type of oven is specifically designed to heat, cook, or dry food. It is not designed for industrial or laboratory use.
2. Do not operate the oven when it is empty.
3. Do not operate this appliance if it has a damaged cord or plug, if it is not working properly, or if it has been damaged or dropped. If the supply cord is damaged, it must be replaced a qualified person to avoid a hazard.
4. To reduce the risk of fire in the oven cavity:
 - When heating food in plastic or paper container, keep an eye on the oven due to the possibility of ignition.
 - Remove wire twist-ties from paper or plastic bags before placing bag in oven.
 - If smoke is observed, switch off or unplug the appliance and keep the door closed to stifle any flames.
 - Do not use the cavity for storage purposes. Do not leave paper products, cooking utensils, or food in the cavity when not in use.
 - The microwave oven is intended for heating food and beverages. Drying of food or clothing and heating of warming pads, slippers, sponges, damp cloth and similar may lead to risk of injury, ignition, or fire.
5. **WARNING!** --Liquid or other food must not be heated in sealed containers since they are liable to explode.
6. Microwave heating of beverages can result in delayed eruptive boiling; therefore, care has to be taken when handling the container.
7. Do not fry food in the oven. Hot oil can damage oven parts and utensils and even result in skin burns.

8. Eggs in their shell and whole hard-boiled eggs should not be heated in microwave ovens since they may explode even after microwave heating has ended.
9. Pierce foods with heavy skin such as potatoes, whole squashes, apples, and chestnuts before cooking.

10. The contents of feeding bottles and baby food jars should be stirred or shaken and the temperature should be checked before serving to avoid burns.
11. Cooking utensils may become hot because of heat transferred from the heated food. Potholders may be needed to handle the utensils.
12. Utensils should be checked to ensure that they are suitable for use in microwave oven.
13. **WARNING!** --It is hazardous for anyone other than a trained person to carry out any service or repair operation which involves the removal of any cover which gives protection against exposure to microwave energy.
14. This product is Group 2 Class B ISM equipment. The definition of Group 2 which contains all ISM (Industrial, Scientific, and Medical) equipment in which radio-frequency energy is intentionally generated and/or used in the form of electromagnetic radiation for the treatment of material, and spark erosion equipment. For Class B equipment is equipment suitable for use in domestic establishments and in establishments directly connected to a low voltage power supply network which supplies buildings used for domestic purpose.
15. This appliance is not intended for use by persons (including children) with reduced physical, sensory, or mental capabilities, or lack of experience and knowledge, unless they have been given supervision or instruction concerning use of the appliance by a person responsible for their safety.
16. Children should be supervised to ensure that they do not play with the appliance.
17. The microwave oven is only used in freestanding.
18. **WARNING!** --Do not install oven over a range cook top or another heat-producing appliance. If installed could be damaged and the warranty would be avoided.
19. The microwave oven must not be placed in the cabinet.
20. **WARNING!** --The appliance and its accessible parts become hot during use.
21. **WARNING!** --Accessible parts may become hot during use. Young children should be kept away.
22. During use the appliances become hot. Care should be taken to avoid touching heating elements inside the oven, for cooking ranges and ovens.
23. The temperature of accessible surfaces may be high when the appliance is operating.
24. The appliance shall be placed against a wall.
25. Appliance is not to be used by children or persons with reduced physical, sensory, or mental capabilities, or lack of experience and knowledge, unless they have been given supervision or instruction.
26. **WARNING!** --If the door or door seals are damaged, the oven must not be operated

- until it has been repaired by a competent person.
27. The appliances are not intended to be operated by means of an external timer or separate remote-control system.
 28. The microwave oven is for household use only and not for commercial use.
 29. Never remove the distance holder in the back or on the sides, as it ensures a minimum distance from the wall for air circulation.
 30. Please secure the turntable before you move the appliance to avoid damage.
 31. **CAUTION!** --It is dangerous to repair or maintain the appliance by no one other than a specialist, because under these circumstances the cover must be removed which assures protection against microwave radiation. This applies to changing the power cord or the lighting as well. Send the appliance in these cases to a qualified technician.
 32. The microwave oven is intended for defrosting, cooking, and steaming food only.
 33. Use gloves when removing heated food.
 34. Caution! Steam will escape, when opening lids or wrapping plastic/foil.
 35. This appliance can be used by children aged from 8 years and above and persons with reduced physical, sensory, or mental capabilities or lack of experience and knowledge if they have been given supervision or instruction concerning use of the appliance in a safe way and understand the hazards involved. Children should not play with the appliance. Cleaning and user maintenance shall not be done by children unless they are aged from 8 years and above and supervised.
 36. If smoke is emitted, switch off or unplug the appliance and keep the door closed to stifle any flames.

INSTALLATION GUIDE

1. Make sure that all the packing materials are removed from the inside of the door.
2. **WARNING:** Check the oven for any damage, such as misaligned or bent door, damaged door seals and sealing surface, broken or loose door hinges and latches and dents inside the cavity or on the door. If there is any damage, do not operate the oven and contact qualified service personnel.
3. This microwave oven must be placed on a flat, stable surface to hold its weight and the heaviest food likely to be cooked in the oven.
4. Do not place the oven where heat, moisture, or high humidity are generated, or near combustible materials.
5. For correct operation, the oven must have sufficient airflow. Allow 20cm of space

above the oven, 10cm at back and 5cm at both sides. Do not cover or block any openings on the appliance. Do not remove the feet.

6. Do not operate the oven without glass tray, roller support, and shaft in their proper positions.
7. Make sure that the power supply cord is undamaged and does not run under the oven or over any hot or sharp surface.
8. The socket must be readily accessible so that it can be easily unplugged in an emergency.
9. Do not use the oven outdoors.

MICROWAVE COOKING PRINCIPLES

1. Arrange food carefully. Place thickest areas towards outside of dish.
2. Watch cooking time. Cook for the shortest amount of time indicated and add more as needed. Food severely overcooked can smoke or ignite.
3. Cover food while cooking. Covers prevent spattering and help foods to cook evenly.
4. Turn foods over once during microwave cooking to speed cooking of such foods as chicken and hamburgers. Large items like roasts must be turned over at least once.
5. Rearrange foods such as meatballs halfway through cooking both from top to bottom and from the center of the dish to the outside.

GROUNDING INSTRUCTIONS

This appliance must be grounded. This oven is equipped with a cord having a grounding wire with a grounding plug. It must be plugged into a wall receptacle that is properly installed and grounded. In the event of an electrical short circuit, grounding reduces the risk of electric shock by providing an escape wire for the electric current. It is recommended that a separate circuit serving only the oven be provided.

WARNING Improper use of the grounding plug can result in a risk of electric shock.

Note:

1. If you have any questions about the grounding or electrical instructions, consult a qualified electrician or service person.
2. Neither the manufacturer nor the dealer can accept any liability for damage to the oven or personal injury resulting from failure to observe the electrical connection procedures.

The wires in this cable main are colored in accordance with the following code:

Green and Yellow = EARTH

Blue = NEUTRAL

Brown = LIVE

BEFORE YOU CALL FOR SERVICE

If the oven fails to operate:

1. Check to ensure that the oven is plugged in securely. If it is not, remove the plug from the outlet, wait 10 seconds, and plug it in again securely.
2. Check for a blown circuit fuse or a tripped main circuit breaker. If these seem to be operating properly, test the outlet with another appliance.
3. Check to ensure that the control panel is programmed correctly, and the timer is set.
4. Check to ensure that the door is securely closed engaging the door safety lock system. Otherwise, the microwave energy will not flow into the oven.

IF NONE OF THE ABOVE RECTIFIES THE SITUATION, THEN CONTACT A QUALIFIED TECHNICIAN. DO NOT TRY TO ADJUST OR REPAIR THE OVEN YOURSELF.

PRECAUTIONS TO AVOID POSSIBLE EXPOSURE TO EXCESSIVE MICROWAVE ENERGY

1. Do not attempt to operate this oven with the door open since open door operation can result in harmful exposure to microwave energy. It is important not to defeat or tamper with the safety interlocks.
2. Do not place any object between the oven front face and the door or allow soil or cleaner residue to accumulate on sealing surfaces.
3. Do not operate the oven if it is damaged. It is particularly important that the oven door close properly and that there is no damage to the
 - a. Door (bent),
 - b. Hinges and latches (broken or loosened),
 - c. Door seals and sealing surfaces.
4. The oven should not be adjusted or repaired by anyone except properly qualified service personnel.

COOKING UTENSILS GUIDE

1. Microwave cannot penetrate metal. Only use utensils that are suitable for use in microwave ovens. Metallic containers for food and beverages are not allowed during microwave cooking. This requirement is not applicable if the manufacturer specifies the size and shape of metallic containers suitable for microwave cooking.
2. Microwave cannot penetrate metal, so metal utensils or dishes with metallic trim should not be used.
3. Do not use recycled paper products when microwave cooking, as they may contain small metal fragments which may cause sparks and/or fires.
4. Round /oval dishes rather than square/oblong ones are recommended, as food in corners tends to overcook.
5. Narrow strips of aluminum foil may be used to prevent overcooking of exposed areas. But be careful don't use too much and keep 1 inch (2.54cm) between foil and cavity.

The list below is a general guide to help you select the correct utensils.

COOKWARE	MICROWAVE	GRILL	COMBINATION
Heat-Resistant Glass	Yes	Yes	Yes
Non Heat-Resistant Glass	No	No	No
Heat-Resistant Ceramics	Yes	Yes	Yes
Microwave-Safe Plastic Dish	Yes	No	No
Kitchen Paper	Yes	No	No
Metal Tray	No	Yes	No
Metal Rack	No	Yes	No
Aluminum Foil & Foil Containers	No	Yes	No

PART NAMES

1. Door Safety Lock System
2. Oven Window
3. Shaft
4. Roller Ring
5. Control Panel
6. Wave Guide
(Please do not remove the mica plate covering the wave guide)

(Please do not remove the mica plate covering the wave guide)

7. Glass Tray
8. Grill Heater
9. Metal Rack

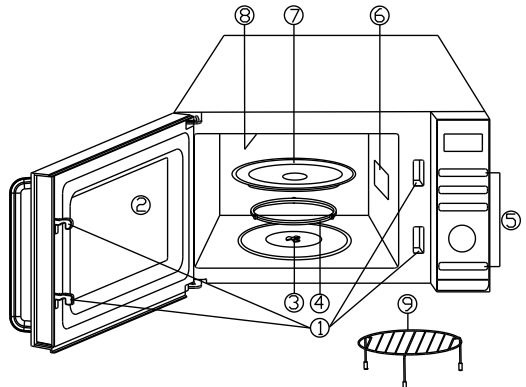

CONTROL PANEL

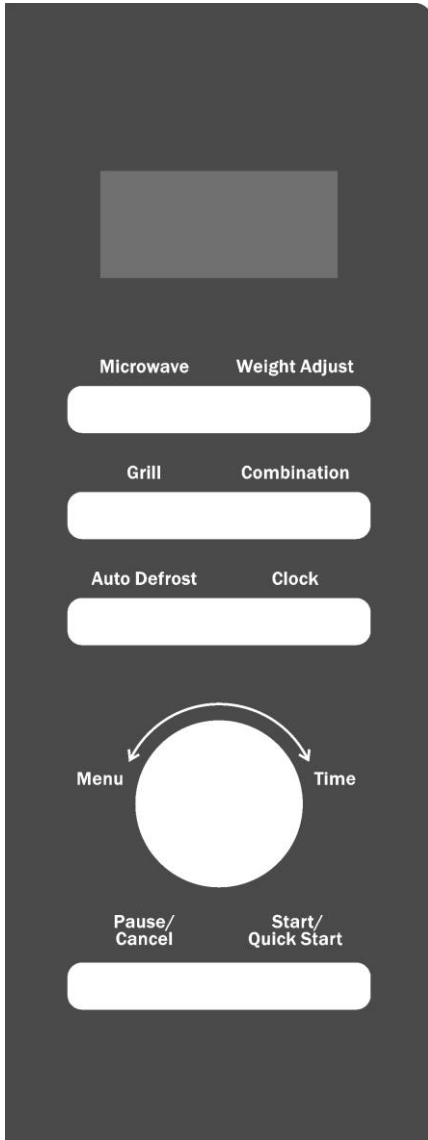

- **MENU ACTION SCREEN**

Time, power, and indicators are displayed.

- **MICROWAVE**

Press to select cooking power level.

- **WEIGHT ADJUST**

Press to set food weight or servings.

- **GRILL**

Press to set grill cooking program.

- **COMBINATION**

Press to set microwave and grill combination cooking program.

- **AUTO DEFROST**

Press to defrost food based on weight.

- **CLOCK**

Press to set clock time.

- **MENU/TIME (dial)**

Turn the dial to set time.

Turn the dial to select auto cooking menus.

- **PAUSE/CANCEL**

Press once to temporarily stop cooking, or twice to cancel cooking altogether.

It is also used to set child lock.

- **START/QUICK START**

Press to start cooking programs.

Simply press it multiple times to set the cooking time and cook immediately at full power level.

OPERATION INSTRUCTIONS

- When the oven is first plugged in, a beep will sound and the display will show "1:01", " " .
- During setting, the system will return to standby mode if there is not any operation within 25 seconds.
- During cooking, if press the PAUSE/CANCEL button once, the program will be paused, then press START/QUICK START button to resume. But if press the PAUSE/CANCEL button twice, the program will be cancelled.
- After cooking ends, the display will show End and beep will sound every two minutes until user press PAUSE/CANCEL button or open the door.
- In the process of operation, press a valid button, the buzzer rings once, but if press an invalid button, the buzzer rings twice.

SETTING THE CLOCK

This is a 12- and 24- hour clock, you can choose to set the clock time in 12- or 24- hour cycle by pressing CLOCK button in standby mode.

1. In standby mode, press the CLOCK button once or twice to choose a 12- hour or 24- hour clock.
2. Turn MENU/TIME dial to set hour digit.
3. Press the CLOCK button once.
4. Turn MENU/TIME dial to set minute digit.
5. Press the CLOCK button once to confirm.

NOTE: During cooking, you can check the current clock time by pressing the CLOCK button.

EXPRESS COOKING

Use this feature to program the oven to microwave food at 100% power conveniently. In standby mode, just press the START/QUICK START button repeatedly to set cooking time (each press to increase 30 seconds, and up to 10 minutes), the oven starts working automatically at full power.

MICROWAVE COOKING

5. In standby mode, press MICROWAVE button repeatedly to select power level.
6. Turn MENU/TIME dial clockwise to set cooking time. The longest time is 95 minutes.
7. Press the START/QUICK START button to confirm.

Press MICROWAVE button to select power level:

Press MICROWAVE Button	Power (Display)
Once	100% (100)
Twice	80% (80)
3 times	60% (60)
4 times	40% (40)
5 times	20% (20)
6 times	0% (00)

NOTE: During cooking, you can check the cooking power level by pressing the MICROWAVE button.

AUTO DEFROST

The defrosting time and power level are automatically set once the food weight is programmed. The frozen food weight ranges from 100 g to 1800 g.

1. In standby mode, press the AUTO DEFROST button once.
8. Press the WEIGHT ADJUST button repeatedly to select food weight.
9. Press the START/QUICK START button to confirm.

NOTE: During defrosting, the system will pause and sound to remind user to turn food over, and then press START/QUICK START button to resume.

GRILL

Grill cooking is particularly useful for thin slices of meat, steaks, chops, kebabs, sausages, and pieces of chicken. It is also suitable for hot sandwiches and au gratin dishes.

1. In standby mode, press GRILL button once.
10. Turn MENU/TIME dial to set cooking time. The longest time is 95 minutes.
11. Press the START/QUICK START button to confirm.

COMBINATION

Combination 1: 30% of whole time for microwave cooking, 70% for grill cooking. Use for cooking fish or au gratin.

Combination 2: 55% of whole time for microwave cooking, 45% for grill cooking. Use for cooking pudding, omelets, baked potatoes, and poultry.

1. In standby mode, press COMBINATION button once or twice to select "COMB1" or "COMB2".
2. Turn MENU/TIME dial to set cooking time. The longest time is 95 minutes.
3. Press the START/QUICK START button to confirm.

AUTO COOK

For the following food or cooking mode, it is not necessary to program the time and the cooking power. It is sufficient to indicate the type of food that you want to cook as well as the weight or servings of this food.

1. In standby mode, turn MENU/TIME dial anti-clockwise to select food code.
12. Press the WEIGHT ADJUST button repeatedly to select the food weight or servings.
13. Press the START/QUICK START button to confirm.

Auto cook menus:

Code	Food	Note
1	Reheat (200-800 g)	1. For Milk/Coffee and Potato, the display will not show the icon "g". 14. For items 8~10, during cooking, the oven will stop to remind user to turn food over, after that, press START/QUICK START to resume. 15. The result of auto cooking depends on factors such as the shape and size of food, your personal preference as to the doneness of certain foods and even how well you happen to place food in the oven. If you find the result at any rate not quite satisfactory, please adjust the cooking time a little bit accordingly.
2	Milk/Coffee (200 ml/cup, 1-3 cups)	
3	Potato (230 g/serving, 1-3 servings)	
4	Fish (200-600 g)	
5	Popcorn (99 g)	
6	Spaghetti (100 g, 200 g, 300 g)	
7	Rice (150-600 g)	
8	Chicken (800-1400 g)	
9	Skewered Meat (100-500 g)	
10	Beef/Mutton (200-600 g)	

CHILD LOCK

Use to prevent unsupervised operation of the oven by children.

To set: In standby mode, press and hold PAUSE/CANCEL button for 3 seconds, a beep will sound, and the indicator light will turn on, the oven will auto enter child lock mode. In the lock state, all buttons are disabled.

To cancel: Press and hold PAUSE/CANCEL button for 3 seconds, a beep will sound, and the indicator light will disappear.

CLEANING AND CARE

1. Turn off the oven and remove the power plug from the wall socket before cleaning.
2. Keep the inside of the oven clean. When food splatters or spilled liquids adhere to oven walls, wipe with a damp cloth. Mild detergent may be used if the oven gets very dirty. Avoid the use of spray and other harsh cleaners as they may stain, streak, or dull the door surface.
3. The outside surfaces should be cleaned with a damp cloth. To prevent damage to the operating parts inside the oven, water should not be allowed to seep into the ventilation openings.
4. Wipe the door and window on both sides, the door seals, and adjacent parts frequently with a damp cloth to remove any spills or spatters. Do not use abrasive cleaner.
5. Steam cleaners should not use.
6. Do not allow the control panel to become wet. Clean with a soft, damp cloth. When cleaning the control panel, leave oven door open to prevent oven from accidentally turning on.
7. If steam accumulates inside or around the outside of the oven door, wipe with a soft cloth. This may occur when the microwave oven is operated under high humidity, and it is normal.
8. It is occasionally necessary to remove the glass tray for cleaning. Wash the tray in warm sudsy water or in a dishwasher.
9. The roller ring and oven floor should be cleaned regularly to avoid excessive noise. Simply wipe the bottom surface of the oven with mild detergent. The roller ring may be washed in mild sudsy water or dishwasher. When removing the roller ring from the cavity floor for cleaning, be sure to replace it in the proper position.
10. Remove odors from your oven by combining a cup of water with the juice and skin of one lemon in a deep microwavable bowl, microwave for 5 minutes. Wipe thoroughly and dry with a soft cloth.
11. When it becomes necessary to replace the oven light, please consult a dealer to have it replaced.
12. The oven should be cleaned regularly, and any food deposits removed. Failure to maintain the oven in a clean condition could lead to deterioration of the surface that could adversely affect the life of the appliance and possibly result in a hazardous.

Please do not dispose of this appliance into the domestic rubbish bin; it should be disposed of at a disposal center provided by your local council.

SPECIFICATIONS

Power Consumption:	230-240V/50Hz, 1400W(Microwave)
	1050W(Grill)
Rated Microwave Power Output:	900W
Operation Frequency:	2450MHz
Outside Dimensions:	300mm(H)×539mm(W)×440mm(D)
Oven Cavity Dimensions:	239mm(H)×354mm(W)×374mm(D)
Oven Capacity:	30Litres

CUSTOMER SERVICE

Australian Customer Service

GAF Control (Sales) Pty Ltd & Maxim Housewares

P.O Box 19

Altona North Victoria 3025

Phone: 1300 659 489

Hours: 9am-5pm (EST) Mon-Fri

www.gafcontrol.com.au

*This product may vary slightly to the product illustrated due to ongoing product development.